



Flashmix Powder/Liquid Mixers

Capacity

Powder incorporation rates of up to 2,000 kg/hr (FMX 30) and 5,000 kg/hr (FMX 45).

Materials of Construction

All product contact parts are constructed in 316L stainless steel.

Motor Specification

TEFV motor is standard other types including stainless steel available upon request.

Sealing

Single EHEDG Approved mechanical shaft seals as standard.

Flashmix Powder/Liquid Mixers

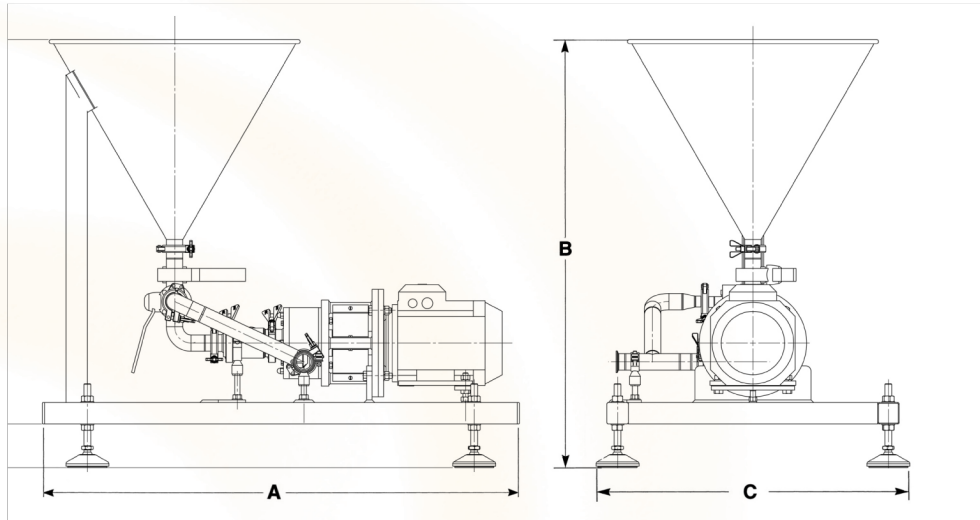

Model	kW	RPM	A	B	C	Hopper Volume	Inlet/Outlet
FMX 30	3.75	3000	1110	995	730	40 litres	1.5"
FMX 45	11	3000	1360	1028	730	40 litres	2"

Powder and liquid flow rates are dependent on powder characteristics and product. Nominal values are given as a guide. All dimensions shown are in millimetres. The dimensions shown are approximate only and certified diagrams should be used for installation purposes. Silverson Machines reserves the right to change dimensions and specifications without notice.

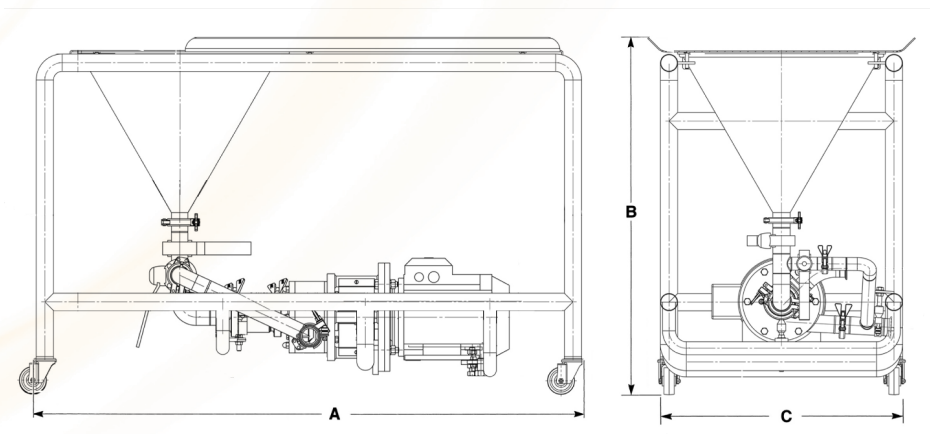

Model	kW	RPM	A	B	C	Hopper Volume	Inlet/Outlet
FMX 30	3.75	3000	1600	1045	730	40 litres	1.5"
FMX 45	11	3000	1600	1045	730	40 litres	2"

Powder and liquid flow rates are dependent on powder characteristics and product. Nominal values are given as a guide. All dimensions shown are in millimetres. The dimensions shown are approximate only and certified diagrams should be used for installation purposes. Silverson Machines reserves the right to change dimensions and specifications without notice.