



## Flashmix Powder/Liquid Mixers

### **Capacity**

Powder incorporation rates up to 250 lbs/min.

### **Materials of Construction**

All product contact parts are constructed in 316L stainless steel.

### **Motor Specification**

TEFC motor is standard. Other types including stainless steel available upon request.

### **Cleaning**

The Flashmix is designed for semi-continuous operation and Cleaning-In-Place (CIP).

### **Sealing**

Single EHEDG Approved mechanical shaft seals as standard.

## Flashmix Powder/Liquid Mixers

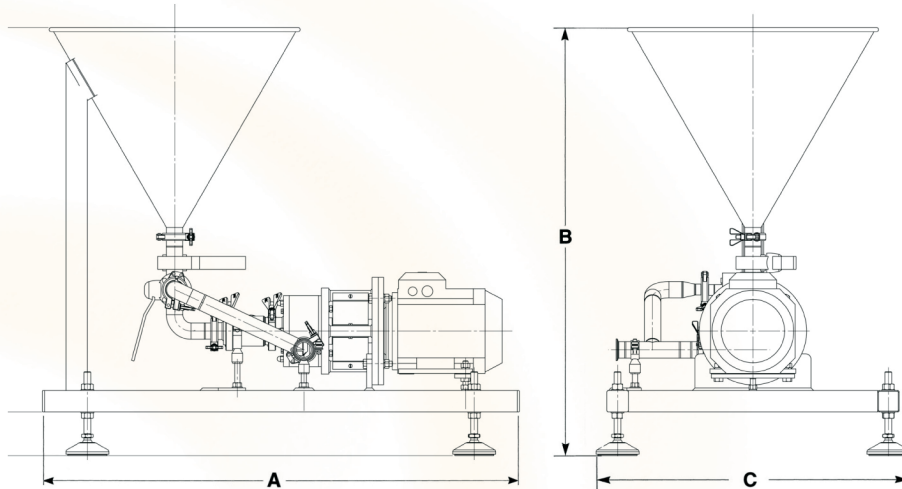

Model	hp	RPM	A	B	C	Hopper Volume	Inlet/Outlet
FMX 30	5	3600	47	30	29	10.5 US Gallons	1.5"
FMX 45	15	3600	54	41	29	10.5 US Gallons	2"

Powder and liquid flow rates are dependent on powder characteristics and product. Nominal values are given as a guide. All dimensions shown are in inches. The dimensions shown are approximate only and certified diagrams should be used for installation purposes. Silverson Machines reserves the right to change dimensions and specifications without notice.

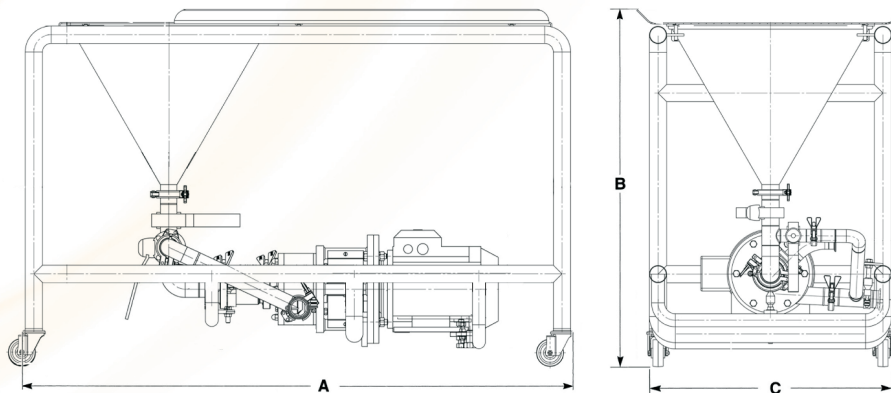

Model	hp	RPM	A	B	C	Hopper Volume	Inlet/Outlet
FMX 30	5	3600	63	41	28	10.5 US Gallons	1.5"
FMX 45	15	3600	63	41	28	10.5 US Gallons	2"

Powder and liquid flow rates are dependent on powder characteristics and product. Nominal values are given as a guide. All dimensions shown are in inches. The dimensions shown are approximate only and certified diagrams should be used for installation purposes. Silverson Machines reserves the right to change dimensions and specifications without notice.